

See discussions, stats, and author profiles for this publication at: <https://www.researchgate.net/publication/331482824>

Intelligent system of LPG gas leakage detection for web-based living house security

Article in *ICIC Express Letters* · February 2019

DOI: 10.24507/iciicelb.10.02.89

CITATIONS

7

READS

6,700

4 authors, including:



SRIWATI .ST .MT

UNIVERSITAS ISLAM MAKASSAR

7 PUBLICATIONS 13 CITATIONS

[SEE PROFILE](#)



Ansar Suyuti

Universitas Hasanuddin

59 PUBLICATIONS 183 CITATIONS

[SEE PROFILE](#)



Andani Achmad

67 PUBLICATIONS 171 CITATIONS

[SEE PROFILE](#)

Some of the authors of this publication are also working on these related projects:



Patch microwave absorber for RF energy harvesting as renewable energy [View project](#)



Doctoral Dissertation 2020 [View project](#)

INTELLIGENT SYSTEM OF LPG GAS LEAKAGE DETECTION FOR WEB-BASED LIVING HOUSE SECURITY

SRIWATI^{1,2}, ANSAR SUYUTI², ANDANI AHMAD² AND ANDI EJAH UMRAENI SALAM²

¹Electrical Engineering Study Program
Faculty of Engineering
Makassar Islamic University
Makassar, South Sulawesi 90222, Indonesia
sriwati.dty@uim-makassar.ac.id

²Department of Electrical Engineering
Hasanuddin University
Gowa 92171, Indonesia
Asuyuti06@yahoo.com; { andani60; ejahsalam }@gmail.com

Received October 2018; accepted December 2018

ABSTRACT. *Intelligent systems for detecting gas leaks are proposed in this study. This tool is used for the safety of residences that use heating equipment with natural gas and petroleum gas (LPG). LPG can leak as a gas or liquid that can cause fires on a small or large scale and can even cause loss of life for its users. This system can also be used for other applications in industries or factories that depend on LPG and natural gas used. The equipment design consists of the main control system: AC-DC converter as a voltage source, temperature sensor, and LPG sensor detects the presence of LPG gas in the air. AC-DC converter is connected with ATmega328 microcontroller control. The communication module is used by the RF module as a connector to the power supply. When the sensor is connected to AC voltage, the AC voltage will send a flashing LED indicator signal that indicates the sensor is functioning and sending a signal that is read in the LCD viewer and computer. The wireless installation system makes it easy for sensors to be moved to various desired rooms.*

Keywords: LPG sensor, Control system, Wireless, LED, AC-DC converter

1. Introduction. LPG (Liquefied Petroleum Gas) is a hydrocarbon gas produced from oil refineries and gas refineries with the main components of propane gas (C₃H₈) and butane (C₄H₁₀). At atmospheric pressure, LPG is gas-shaped, but for ease of distribution, the transformed LPG becomes liquid by applying pressure [1,2]. LPG can leak as gas or liquid. If the liquid leaks, it will quickly evaporate and form a relatively large gas cloud that will fall to the ground because it is heavier than air. Steam LPG can run for long distances along the ground and can collect in waterways or basements. When the gas meets the ignition source, it can burn or explode. LPG can cause cold burns on the skin and can act as asphyxia at high concentrations. Government policy in converting the use of energy from kerosene to LPG (Liquefied Petroleum Gas) gas has prompted many people to use LPG gas stoves as the fuel used for stoves. The government policy turned out to cause many problems. Although LPG gas stoves have more practical advantages in using them from kerosene stoves, they still have drawbacks, namely the dangers they pose if there is a gas leak that results in an explosion and causes a fire and even casualties. Based on data from the National Consumer Protection Agency (BPKN) until June 2010, cases of LPG gas accidents were seen soaring from 2007 to 2010 as shown in Figure 1.

The incident happened on Sunday, February 14, 2016, when Madiman (24), an employee of a gas selling agent located in Ruko Serpong Park, South Tangerang, Banten, was

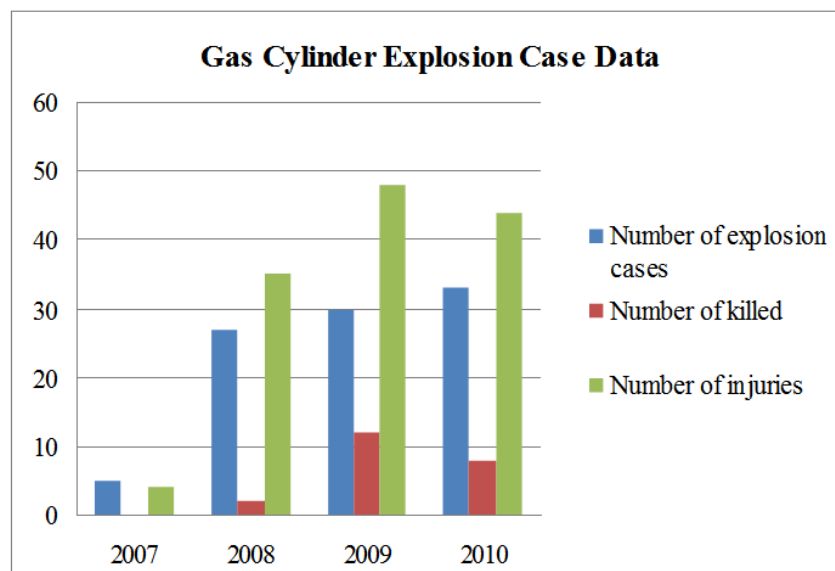

FIGURE 1. Graph of data on LPG gas cylinder explosion cases according to BPKN June 2010 [3]

arranging the gas he sold. Suddenly the gas exploded and the victim suffered burns in almost all parts of his body. According to the local police, this explosion was allegedly caused by a leak in an LPG tube. A similar incident also happened on Tuesday, December 8, 2015, and ago, an explosion occurred in Kebayoran Lama, South Jakarta. After an examination by South Jakarta Metro Police officers and the Gegana team of the Metro Jaya Police Mobile Brigade Unit, a pure explosion was caused by a leaked 3 kg LPG tube. Seven residents of Alue Kereiliki Village, Banda Baro District, North Aceh, Aceh, were burned. They suffered burns all over the body due to a 12 kg LPG tube in his house that leaked to snatch fire and injure him. A 50-kilogram gas cylinder exploded in Penjaringan, North Jakarta. The incident left 1 person dead and 3 others injured. The incident occurred at a gas store on Jl G RT 04/17, No 2, Pejagalan, Penjaringan, North Jakarta. Head of Criminal Investigation Unit of Penjaringan Police, Commissioner Rahmat Sujatmiko, said the incident occurred at around 08.50 W. The various cases of fires caused by LPG gas leaks and the lack consumer knowledge regarding how to install and place LPG tubes also contributed to the many incidents of fire and LPG gas explosions. The research for early protection of LPG gas leak has been widely carried out, the concept of this tool in the form of a voltage source (power supply) of 5V flowing power to the microcontroller to process data carried out by the MQ-2 sensor in the form of gas leak detection. If the gas sensor detects propane gas ($200\text{ppm} \leq 5000\text{ppm}$), then the sensor will send data so that the buzzer sounds, the fan rotates to neutralize the gas odor, and the DC motor will automatically release the regulator. After the release regulator sends data to the SIM900 module to send information in the form of SMS to the owner of the gas cylinder. The SMS received by the owner of the LPG gas cylinder can auto-reply so that the process of turning off the buzzer and fan does not have to go through the research button but can use reply SMS [4].

This tool uses two microcontrollers that function as processors. The first microcontroller is used to regulate the system contained in the house, while the second microcontroller is used to regulate the information system at the security post. The system inside the house has two gas sensors and a light sensor, the gas sensor functions to detect if there is an LPG gas leak. If there is a gas leak, then the sensor will send a signal to the ADC (Analog to Digital Converter) which is then forwarded to the microcontroller, to turn on the exhaust fan which will blow and flow the LPG gas out of the room and the buzzer

as a sign of danger to the occupants of the house. In addition, the microcontroller also sends signals through the ASK transmitter to the security post that there is a gas leak at the residents' homes. The light sensor works to detect if a fire arises due to the gas leak. When a fire occurs, the light sensor will send a signal to the ADC which is then forwarded to the microcontroller. The microcontroller will turn on the solenoid valve on the fire extinguisher tube to extinguish the fire and buzzer as a sign of danger for the occupants of the house [5]. The LPG gas leak detection system built consists of 3 Sensor Devices, M2M Application, and M2M Platform. Sensor device consists of an Arduino Uno R3 microcontroller, I/O Expansion shield, an MQ-6 sensor as LPG sensor, and Xbee S2 which functions as a transmitter. On the M2M Application side, there are 2 different functions, where the first one can be used as a Gateway using Xbee S2 which is installed on a laptop/PC which will hold data from all three sensor devices to be processed. Gateway is also in charge of sending data that has been processed to Open MTC which will be stored in OpenMTC [6].

This study detects changes in gas concentration, activates audiovisual alarms, and sends signals to the receiver. It consists of a gas detection sensor, a sensing circuit, a microcontroller, and an RF transmission system. Gas detection is carried out using solid-state gas sensors (Models: MQ-5, Hanwei Electronics Co., Ltd, China) which are sensitive to LPG, natural gas (or methane) and other gases such as CO and H₂ but not sensitive to air; therefore, the reading is not affected by the presence of air. A receiver module is a moving unit that receives the circumstances of gas detection and the transmitter module. It consists of an RF Receiver (Model: SILEX-418, Linx Technologies, USA) and a microcontroller (PIC-16F877A, Microchip Technology Inc., USA). After receiving data from the transmitter, the RF receiver sends it to the microcontroller. The microcontroller reads the data, decodes it, and displays it to the output device (red light emitting diode, buzzer, and LCD screen) [7]. A new approach to gas leak detection at low concentrations, with the help of MQ-6 gas sensors. The sensor sends a signal to the microcontroller. Then the microcontroller sends an active signal to other devices that are connected externally. Efficiency and microcontroller memory can be increased if the Philips microcontroller is used instead of AT89C51. Multiple SMS can be sent by changing the GSM module programming. To change the SIM card we have to make changes in the program [8].

2. Proposed Research Methods. Utilization of sensors for monitoring gas emissions has been carried out, for example, KE25 for oxygen, MQ136 for SO₂, TGS2201 for NO_x, MQ7 for CO and MQ2 for the opacity of smoke in the air [9]. The schematic diagram that we propose can be seen in Figure 2. In Figure 3 seen, we approach the sensor MQ-6 to detect LPG gas leaks with the main control system consisting of AC-DC converter, a device that converts the AC220 volt voltage to a 5V DC voltage that is used as a voltage source on the system. A current sensor is a sensor to detect current. The sensor used is a non-invasive sensor with a clamping method. The voltage sensor is a voltage sensor that uses ZMPT101B. This sensor detects voltage in the mesh. The controller is a control component that uses ATmega328. RF module is a communication module used to connect the main control circuit with LPG sensor circuit and temperature. USB to Serial is a device to connect the control system with a computer/laptop via a USB connection.

2.1. The LPG sensor & temperature device system. It consists of an AC-DC converter, a device that converts the AC220 volt voltage to a 5V DC voltage that is used as a voltage source on the system. The temperature sensor is a temperature sensor with type DHT11. Sensor LPG is a sensor to detect LPG of gas in the air. The controller is a control component that uses ATmega328. Module RF is a communication module used to connect the main control circuit with an application control circuit (Laptop). Figure 4 is the chart of LPG sensor & temperature devices.

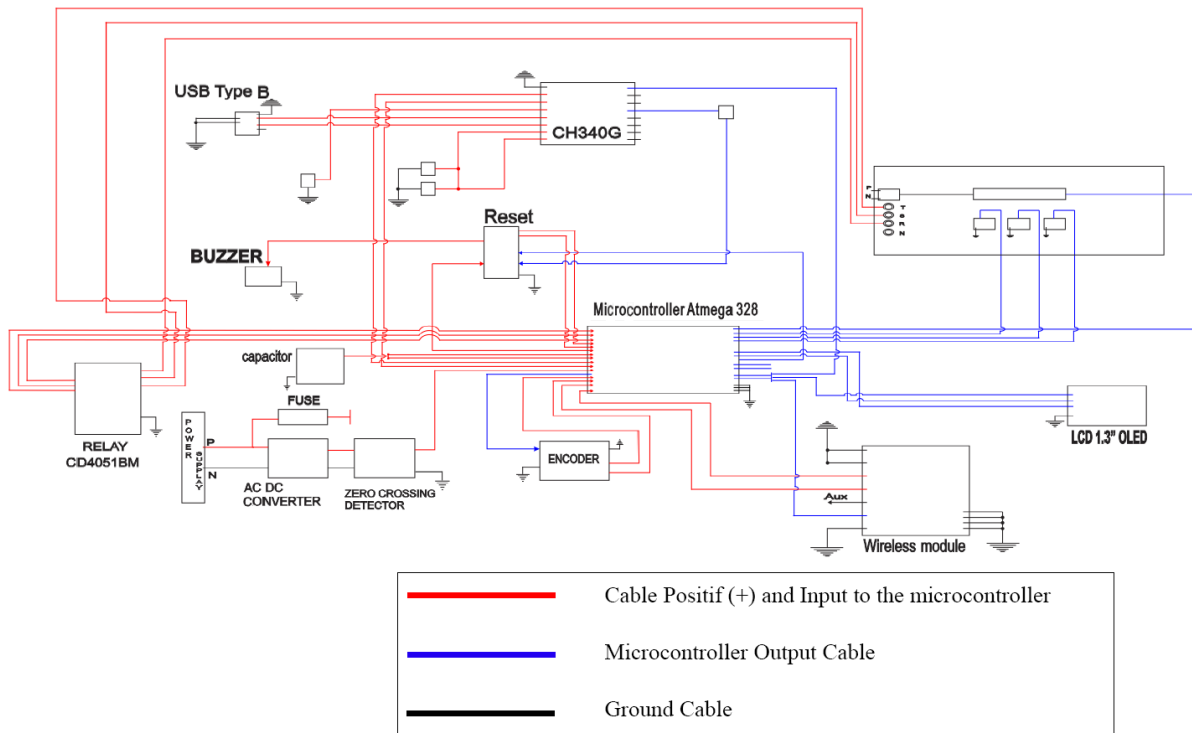

FIGURE 2. (color online) Diagram schematic of LPG gas leak detection

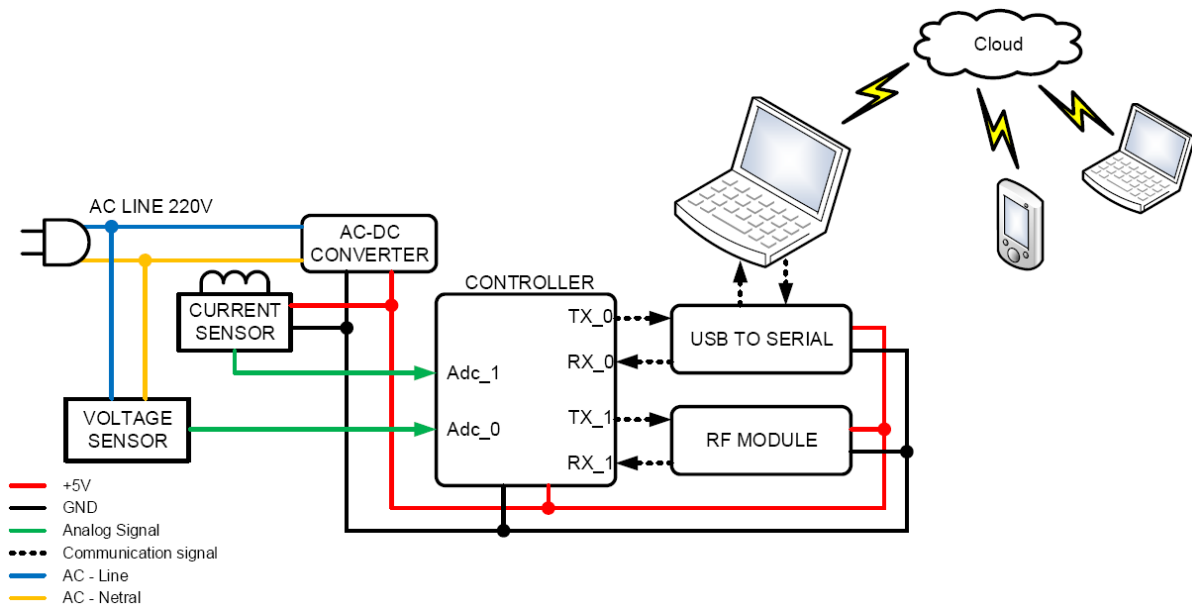

FIGURE 3. (color online) Main control system chart

2.2. MQ-6 LPG measurement. Sensor to perform LPG gas readings, the ATmega328 microcontroller requires an external device in the form of an input device or an input module in the form of an MQ-6 LPG sensor. Sensor gas MQ-6 is used to detect LPG, ISO-butane, propane with sensitivity high. The MQ-6 gas sensor has a small sensitivity to alcohol and smoke cigarette. The MQ-6 gas sensor is a sensor that has a fast response to LPG (Liquid Petroleum Gas) which can be used in a simple drive circuit stable and durable. MQ-6 gas sensors commonly used in equipment detect gas leaks in the household and industrial activities, which are suitable for detecting LPG, iso-butane, propane and LNG, as well as avoiding interference from alcohol detection, cooking smoke and

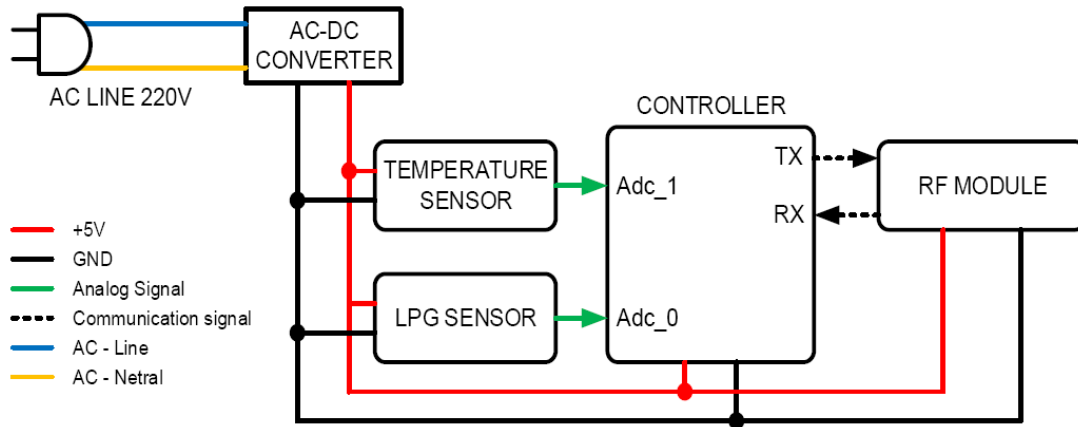

FIGURE 4. (color online) Chart of LPG sensor & temperature devices

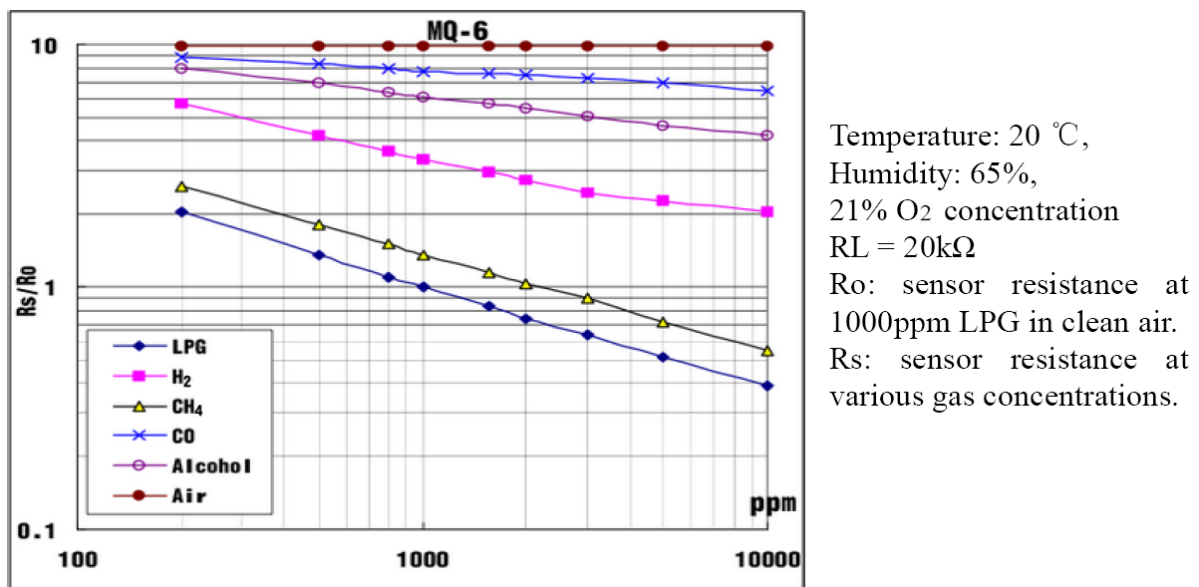

FIGURE 5. Sensitivity of MQ-6 (Source: MQ-6 Datasheet)

cigarettes to reduce detection errors. Its sensitivity has Sensing Resistance (R_s): 10KΩ-60KΩ (1000ppm LPG). Standard Conditions Detection: Temp: 20° ± 2° Vc: 5V ± 0.1 Humidity: 65% ± 5% Vh: 5V ± 0.1. Detection Range: 200-10000ppm LPG, iso-butane, propane, LNG. Figure 5 shows sensitivity of MQ-6.

3. The Device Operating System and Testing. The circuit is the first temperature connected to the AC voltage source. Sensor circuits can be placed in areas far from the main circuit. The LED indicator on the sensor circuit will blink which indicates that the circuit is functioning and the process of sending sensor data to the main circuit has taken place. The main circuit will display the temperature sensor and LPG sensor readings, as well as the reading value of the sensor circuit. The reset button on the main circuit serves to reset the circuit. The rotary switch is used to move the display mode. The program is intended to ensure that the language created by the program can be run and function as expected in the circuit. This process requires additional devices to connect the circuit with the compiler called Downloader. In the main circuit, the downloader uses USB to Serial which is connected directly to the Arduino IDE compiler.

3.1. Microcontroller installation.

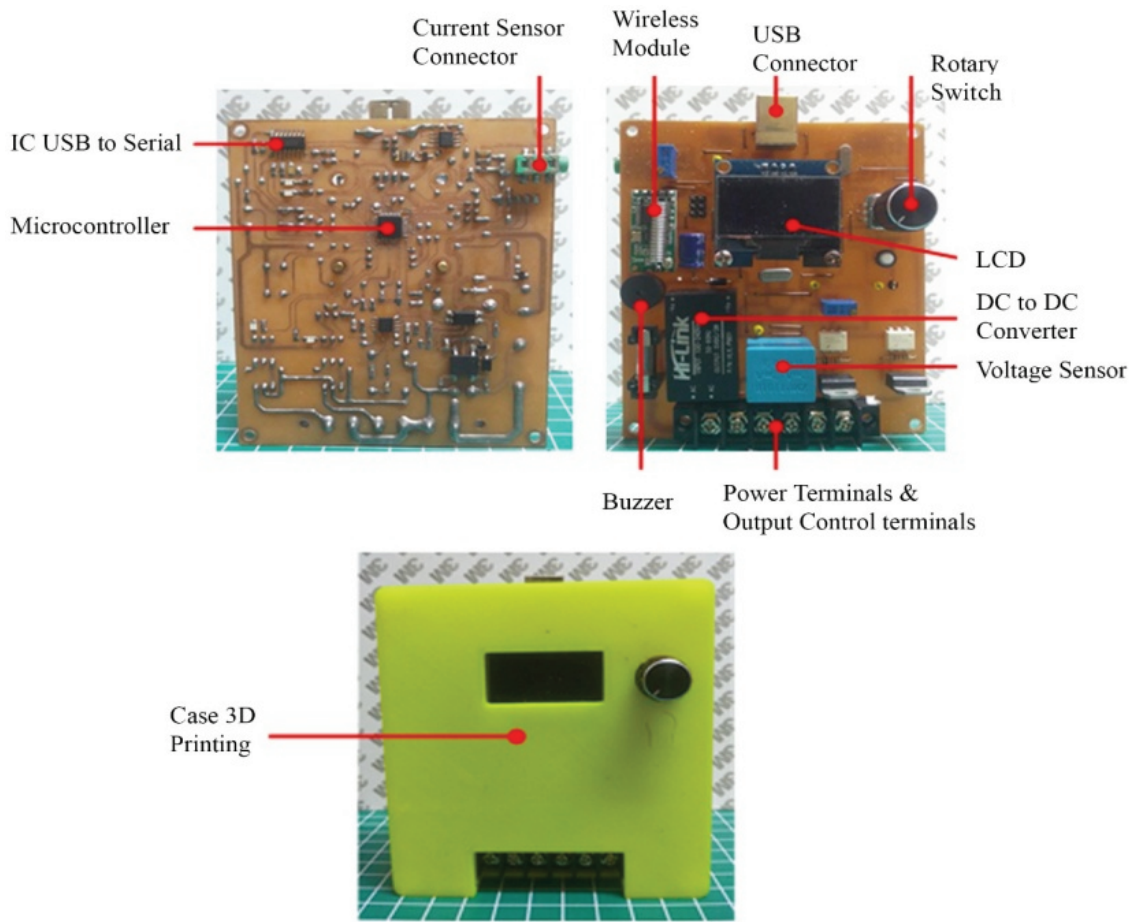

FIGURE 6. Microcontroller installation

3.2. Installation of MQ-6 sensor.

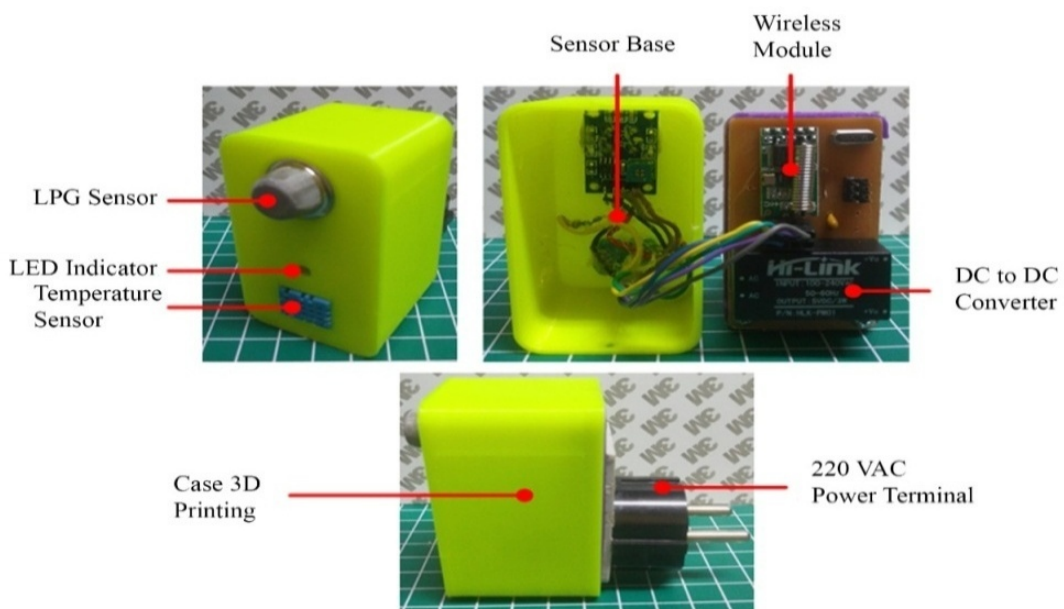

FIGURE 7. Installation of MQ-6 sensor

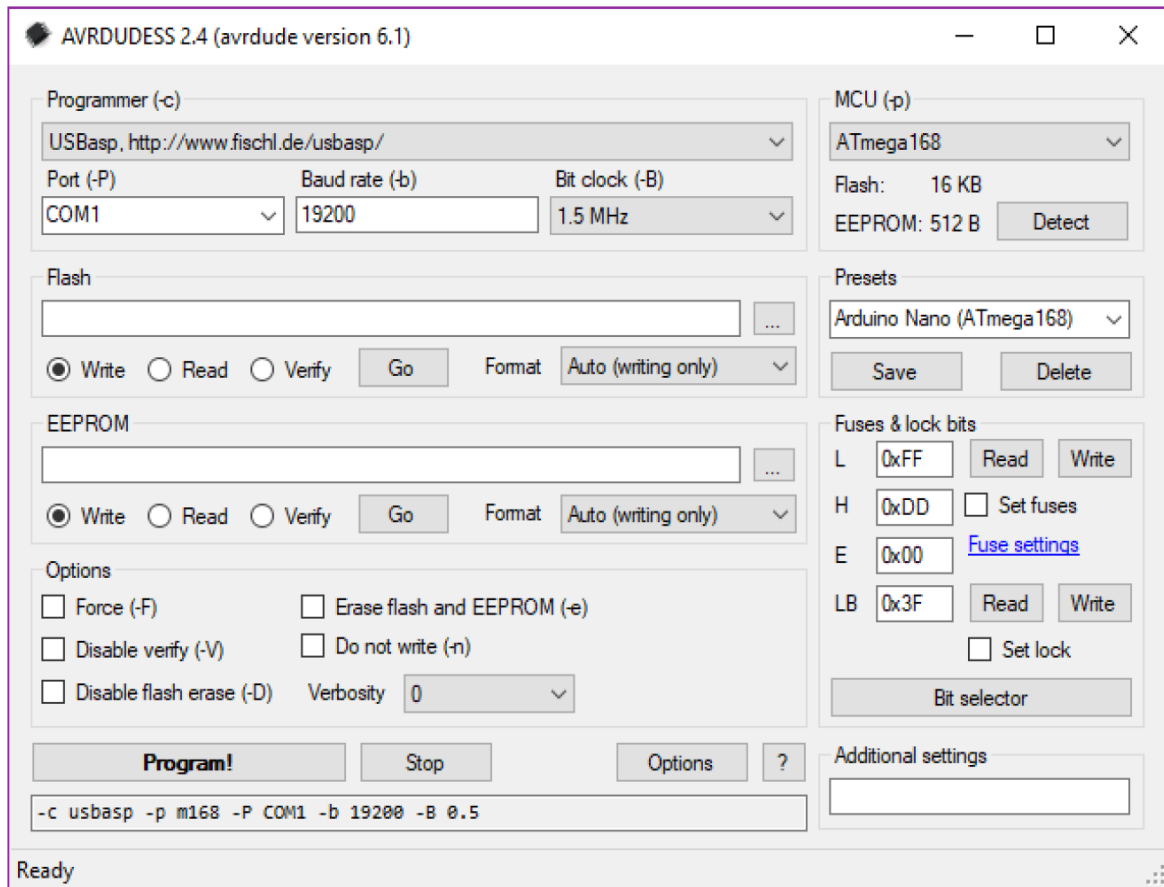

FIGURE 8. AVR dude main view

TABLE 1. Testing on web views

No	Data retrieval	Temperature (°C)	Tegangan (V)	Sensor LPG (ppm)
1	Observation1	33	220	2
2	Observation2	33	221	2
3	Observation3	33	222	2
4	Observation4	33	219	3
5	Observation5	33	221	1

While the temperature sensor circuit and LPG use USB ASP as a downloader and require additional applications namely AVR dude. Figure 8 shows AVR dude main view.

This is the code for sending (flashing) LED flashing programs as described above to the microcontroller. To use the microcontroller to an external clock add the code from the website calculator fuse.

4. Conclusion. Implementation of a complete prototype system for gas leak detection has been tested and can be accessed via the Internet, as a preventive matter against the danger of gas leakage as shown in Figure 9. The proposed system can detect changes in gas concentration over long distances both at home and outside the home, and can provide convenience in the system to detect gas leaks. Furthermore, the system calibrates at a certain time interval, because the sensitivity of the sensor with temperature is placed in the same container so that it can measure humidity simultaneously. The proposed system was tested by introducing a gas sensor and temperature connected to the power supply within a distance of 15 m from the LPG that is being used in the house and its appearance



FIGURE 9. A prototype of LPG gas leak detection system

is read on the LCD and computer. This operation produces detectable quantities and the temperature at LPG data retrieval reads 2 ppm and 33°C temperature. With a wireless installation system, sensors can also be moved to various desired rooms.

REFERENCES

- [1] N. I. Ilahi et al., Early leakage protection system of LPG (Liquefied Petroleum Gas) based on ATmega 16 microcontroller, *IOP Conference Series: Materials Science and Engineering*, 2018.
- [2] A. Bahadori, Chapter 12 – Liquefied Petroleum Gas (LPG) recovery, in *Natural Gas Processing*, A. Bahadori (ed.), Gulf Professional Publishing, Boston, 2014.
- [3] B. P. K. Nasional, *Results of the BPKN Study on Food Related to Consumer Protection*, 2007.
- [4] A. P. Berlilana and I. M. Raharjo, *LPG Gas Leakage Detector and Safety through SMS Based on ATMEGA328 Microcontroller*, STMIK Amikom Purwokerto, Purwokerto, 2016.
- [5] A. S. Burhan, M. Muljono and E. S. Hasrito, Fire prevention equipment caused by leakage of Liquefied Petroleum Gas (LPG), *Tesla Untar*, vol.15, no.2, pp.153-164, 2017.
- [6] D. Permana, M. Abdurrohman and N. A. Suwastika, LPG gas leak detection system using machine-to-machine multi sensors, *Proc. of Engineering*, vol.2, no.2, 2015.
- [7] L. Fraiwan et al., A wireless home safety gas leakage detection system, *The 1st Middle East Conference on Biomedical Engineering (MECBME)*, 2011.
- [8] A. Shrivastava et al., GSM based gas leakage detection system, *International Journal of Emerging Trends in Electrical and Electronics*, vol.3, no.2, 2013.
- [9] A. Suyuti, M. Tola, M. S. Pallu, N. Harun, Syafaruddin and T. Hiyama, Simple and portable gas emission detector design using microcontroller ATmega16, *ICIC Express Letters, Part B: Applications*, vol.4, no.1, pp.13-18, 2013.
- [10] *H & S A*, https://www.hsa.ie/eng/Topics/Liquid_Petroleum_Gas_LPG_/#top, 2018.
- [11] N. Tri Laksono, *detikNews/News/News Details [February 20, 2017, 14.11 WIB]*, <https://news.detik.com/news/d-3427031/tube-gas-burst-in-netting-1-person-killed-and-3-wound>, 2017.
- [12] D. H. Maulana, *detikNews/News/News Details [December 29, 2017, 16.09 WIB]*, <https://news.detik.com/berita/d-3790675/LPG-12-kg-leak-7-person-burnt-tube>, 2017.